

Policy integration and institutional arrangements: experiences and lessons from Denmark, England and Germany

Dr Dominic Stead

OTB Research Institute for Housing, Mobility and Urban Studies
Delft University of Technology
The Netherlands

d.stead@otb.tudelft.nl

<http://www.otb.tudelft.nl>

Content

- introduction
- definitions and concepts
- impact assessment techniques
- institutional arrangements
- conclusions

Introduction

“Sustainability requires that policy-making for urban travel be viewed in a holistic sense: that planning for transport, land-use and the environment no longer be undertaken in isolation one from the other... Without adequate policy co-ordination, the effectiveness of the whole package of measures and their objectives is compromised.”

European Conference of Ministers of Transport (2001)

- the need for policy integration is widely supported
- BUT information about how to do so (especially in terms of institutional arrangements) is hard to find

The research

- experiences of policy integration in local authorities in Denmark, England and Germany:
 - Copenhagen
 - Cambridgeshire and Peterborough
 - Freiburg
- focus on the integration of three specific areas of policy:
 - land use planning
 - transport
 - environment
- based primarily on in-depth interviews with key actors involved in policy making
- research carried out in 2002 for the Netherlands Agency for Energy and the Environment (NOVEM)

Definitions and concepts

- various terms in the policy integration literature, such as:
 - coherence
 - consistency
 - collaboration
 - co-operation
 - coordination
 - integration
- some research sees some differences between these terms; some does not
- hierarchy of terms proposed:
 - **policy co-operation** = dialogue and information
 - **policy coordination**, **policy coherence** and **policy consistency** (all quite similar) = co-operation plus transparency and some attempt to avoid policy conflicts (but similar goals not necessarily used)
 - **policy integration** and **joined-up policy** = policy coordination plus joint working, attempts to create synergies between policies (win-win situations) and the use of the same goals to formulate policy

Hierarchy of terms

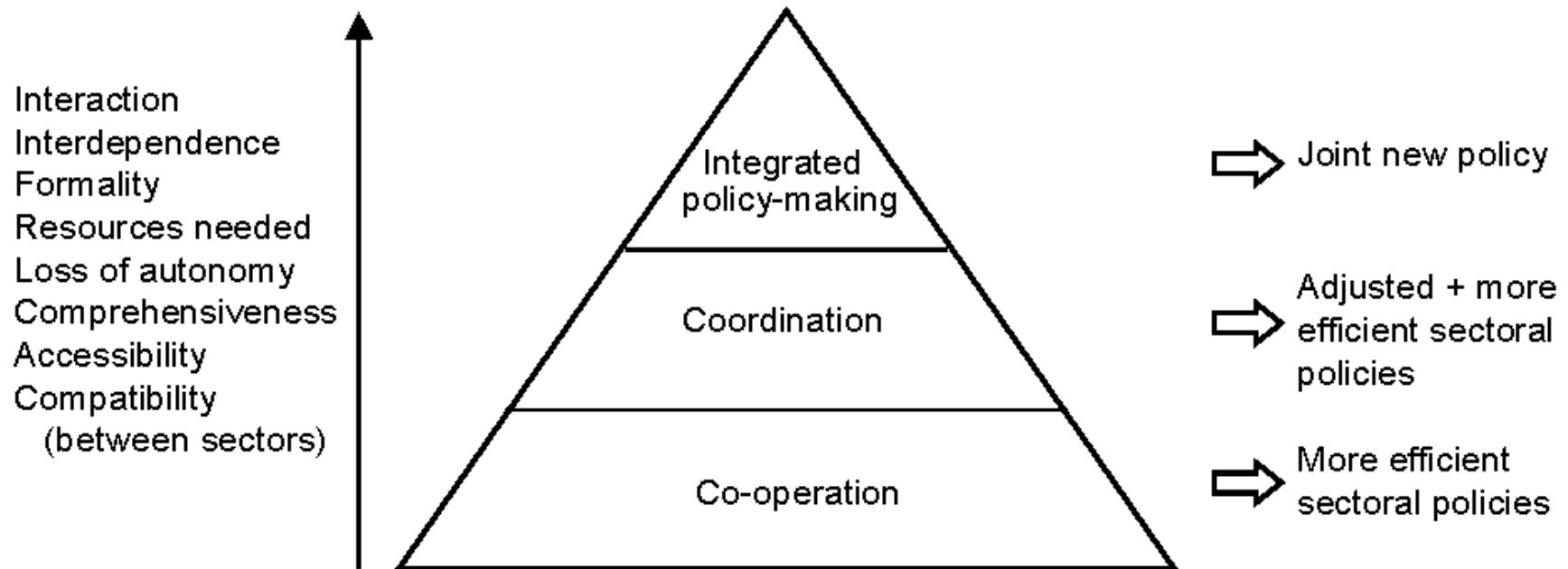

Examples of different types of policy integration

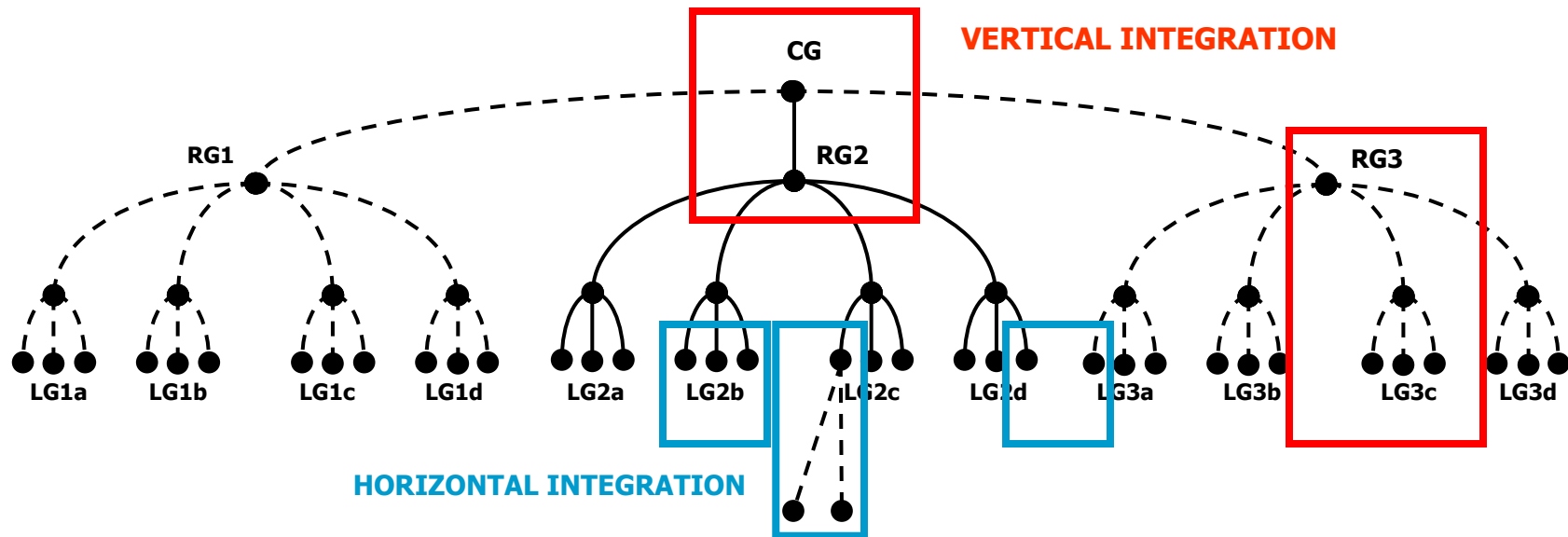

Integration between different tiers of government, different departments, adjacent authorities and other agencies.

Impact assessment techniques

- more impact assessment techniques in England than in Denmark or Germany with potential importance for policy integration
- BUT this does not mean that policy integration is any more advanced in England than in Denmark or Germany!
- some examples include:
 - sustainability appraisal
 - transport assessments
 - air quality management
 - causal chain analysis

Impact assessment techniques

sustainability appraisal

- required as part of the process of preparing regional planning policies
- compatibility of policies
- health impact assessment of the Cambridgeshire and Peterborough structure plan carried out alongside the sustainability appraisal

transport assessments

- required to be submitted alongside the planning application for new developments with significant transport implications
- interesting opportunity for transport and land-use agendas to come together

Impact assessment techniques

air quality management

- air quality considerations required to be taken into account when preparing land use plans and transport policies
- where air quality is poor (or is forecast to be poor in the future), local authorities are required to prepare an action plan showing how the air quality problem will be tackled through planning, transport, etc

causal chain analysis

- local transport plans (LTPs) must show a clear link between objectives, measures and outputs
- causal chain analysis is one way of doing this
- stimulates inter-sectoral considerations

Example of causal chain analysis

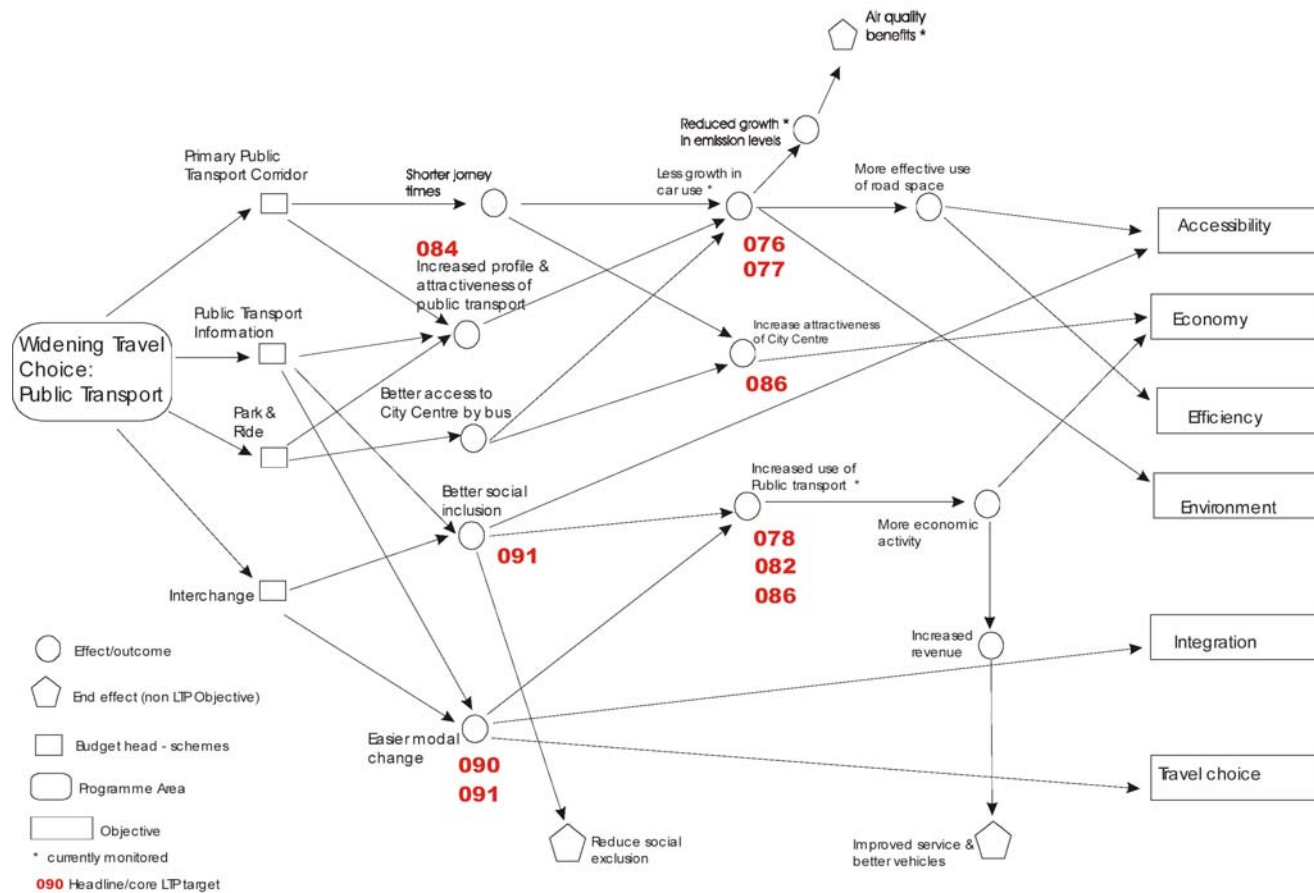

Institutional arrangements

joint team working

- considered more effective in terms of time, resources and expertise
- possible mechanism for saving money and improving policy co-ordination

political support

- policy implementation requires political support for policy approval
- securing this political support is sometimes problematic because decisions may only have long-term and/or rather intangible impacts

shared budgets and responsibilities

- consensus that policy integration is more effective when there is a balanced (fairly even), clear division of budgets and responsibilities

Institutional arrangements

shared goals

- policy integration requires a set of shared goals, which necessitates procedures, rules and guidelines that promote policy consistency
- information, communication and professional training also important

procedures and guidelines

- no formal procedures set out by local or national government to formulate integrated policy
- most procedures currently developed through trial-and-error

key individuals and networks

- importance of strongly motivated officers and/or extensive professional networks
- benchmarking and staff mobility can help to extend professional networks

Conclusions and lessons

- no single measure or technique can bring about policy integration
- similar approaches in different settings may have different effects
- there is no single model for effective policy integration
- various factors can affect the impact of different approaches (e.g. cultural, political and organisational factors)
- HOWEVER, some of the examples of instruments, techniques and institutional arrangements offer potentially promising contributions to policy integration in a variety of situations
- integrated **policies** provide no guarantee of integrated **practice** (implementation)
 - integrated policy should not be seen as an end in itself but as a potential means of influencing more integrated outcomes

END